

HURST

HURST PERFORMANCE SERIES BOILERS

OPTIONAL SKID PACKAGES

Skid Mounted,
Piped & Wired



FEEDWATER SYSTEMS

BLOWN DOWN SEPARATORS

Shipping Container Friendly Up to 800 Horsepower

Standard Steam Trim

- Operating & high limit pressure controls
- Modulating pressure control (when appl.)
- Water column with drain valve, gauge glass, combination low water cut-off & pump control
- Probe Aux, L.W.C.O. w/ Manual Reset Steam pressure gauge, syphon & test cock
- Stack Thermometer, Water column drain valve
- Safety relief valve(s) per ASME Code

Standard Water Trim

- Operating & high limit temperature controls
- Modulating temperature control (when appl.)
- Probe type low water cut-off control with Manual Reset
- Combination pressure & temperature gauge
- Hot water return baffle for shock resistance
- Safety relief valve(s) per ASME Code
- Stack Thermometer

HBC-09517
01/2011



HURST

BOILER & WELDING CO., INC

AVAILABLE WITH LOW NOX

SERIES 250

2-PASS SCOTCH MARINE DESIGN
with Semi-Wetback Construction

HIGH & LOW
PRESSURE BOILER.
Capacities From 20 to 1000 BHP.
670 to 33475 MBTU/HR.

STEAM
Pressures From 15-450 PSI.

HOT WATER
Section I and Section IV



Shown with
OPTIONAL SKID PACKAGE

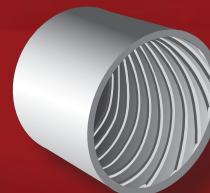

ENHANCED FIRE TUBES

Advanced technology fire tubes with enhanced
heat transfer characteristics.



 hurstboiler.com

HURST BOILER & WELDING CO., INC.

100 Boilermaker Lane • Coolidge, GA 31738-0530

Tel: (229) 346-3545 • Fax: (229) 346-3874

email: info@hurstboiler.com

HURST PERFORMANCE SERIES BOILERS

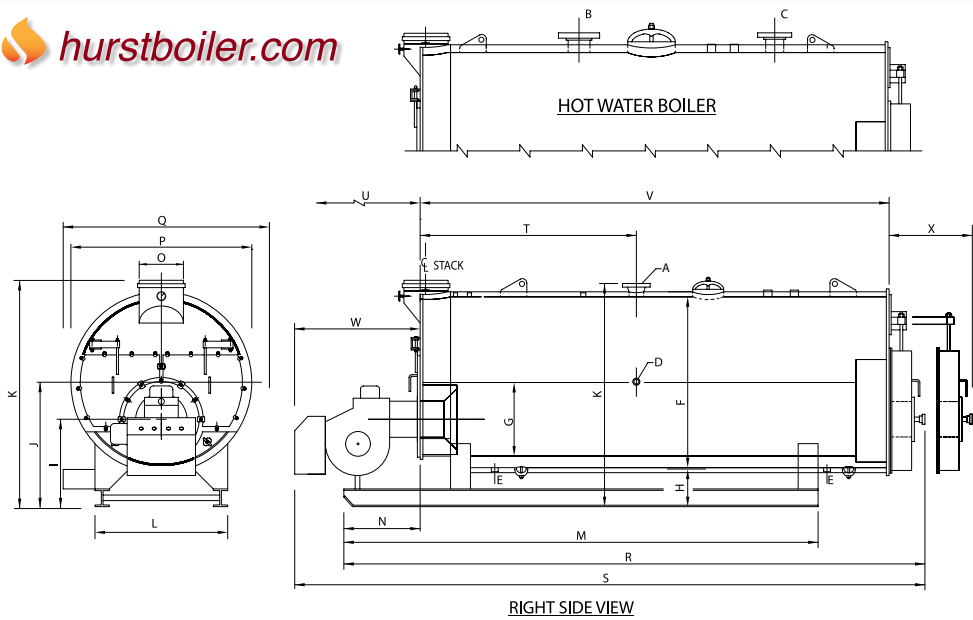

RIGHT SIDE VIEW

Inspected and registered with the National Board of Boiler & Pressure Vessel Inspectors.



Designed, constructed and stamped in accordance with the requirements of the ASME Boiler Codes.

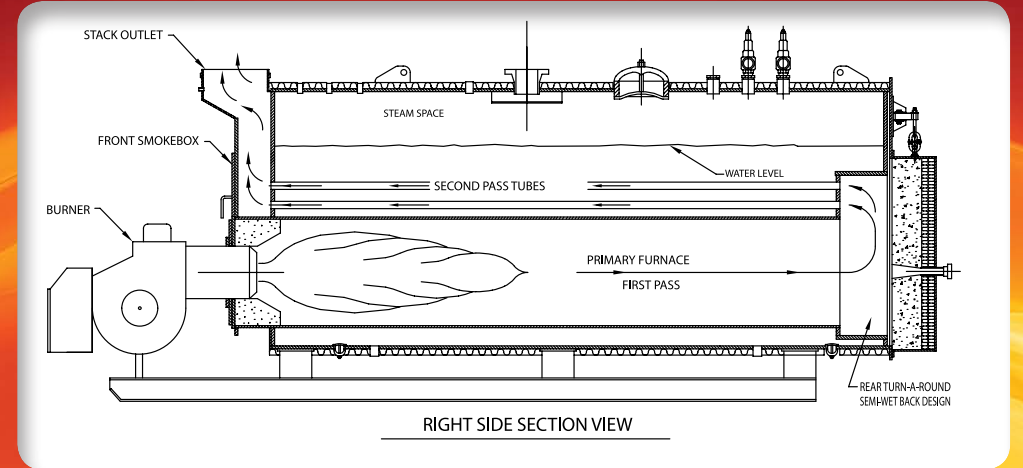

RIGHT SIDE SECTION VIEW

BOILER SPECIFICATIONS

BOILER HORSEPOWER			20	25	30	40	50	60	70	80	100	125	150
STEAM OUTPUT	FROM & @ 212"	LBS/HR	690	862	1035	1380	1725	2070	2415	2760	3450	4312	5175
GROSS OUTPUT		MBH	670	837	1004	1339	1675	2008	2343	2678	3348	4184	5021
FIRING RATE GAS	1,000 BTU/CF	CFH	840	1050	1260	1680	2100	2520	2940	3360	4200	5250	6300
FIRING RATE LP GAS	91,500 BTU	GPH	9.2	11.5	13.8	18.4	23	27.5	32.1	36.7	45.9	57.3	68.8
FIRING RATE OIL #2	140,000 BTU	GPH	6	7.5	9	12	15	18	20.7	24	30	37.5	45
FIRING RATE HEAVY OIL	150,000 BTU	GPH	5.6	7	8.4	11.2	14	16.8	19.3	22.4	28	35	42
A	*NOTE: 1 STEAM OUTLET SIZE	150 PSI	IN	1.25	1.25	1.5	1.5	2	2	2.5	2.5	4	4
A	*NOTE: 2 STEAM OUTLET SIZE	15 PSI	IN	3	3	4	4	4	6	6	6	6	8
B	*NOTE: 2 WATER SUPPLY SIZE	30 PSI	IN	3	3	3	4	4	4	6	6	6	8
C	*NOTE: 2 WATER RETURN SIZE	30 PSI	IN	2.5	2.5	3	3	4	4	4	6	6	6
D	FEEDWATER CONNECTION SIZE		IN	0.75	0.75	0.75	1	1	1.25	1.25	1.25	1.25	1.25
E	BLOWDOWN CONNECTION (BTM)	HIGH PRESS.	IN	1	1	1	1.25	1.25	1.25	1.25	1.25	1.25	1.25
E	BLOWDOWN CONNECTION (BTM)	LOW PRESS. & HW	IN	1.25	1.25	1.25	1.25	1.25	1.5	1.5	1.5	1.5	1.5
F	SHELL INSIDE DIAMETER		IN	40	40	40	42	42	46	46	48	48	54
G	FURNACE O.D.		IN	16	16	18	18	20	22	22	24	26	28
H	SHELL TO FLOOR		IN	14	14	14	14	14	14	14	14	14	14
I	CENT.LINE FURN. TO FLOOR		IN	27.31	27.31	27.31	27.31	29.188	29.13	29.13	31.688	31.88	34.438
J	CENT.LINE BOILER. TO FLOOR		IN	34.31	34.31	34.31	35.31	35.31	37.313	37.313	38.313	35.313	41.313
K	STACK OUTLET HEIGHT		IN	60.63	60.63	60.63	62.63	62.63	66.63	66.63	68.63	68.63	74.63
L	SKID & SADDLE WIDTH		IN	36	36	36	36	36	40	40	40	40	44
M	SKID LENGTH		IN	104	104	104	118	124	138	138	138	172	176
N	SKID TO FRONT PLATE		IN	21.25	21.25	21.25	23.25	22.25	24.25	24.25	24.25	27.25	30.188
O	STACK OUTSIDE DIA.		IN	10	10	10	12	12	14	14	14	16	16
P	WIDTH WITH NO TRIM		IN	45.625	45.625	45.625	48.63	48.63	52.13	52.13	54.13	60.13	60.13
Q	WIDTH WITH STD. TRIM		IN	55	55	55	58	58	64	64	64	66	72
R	LENGTH WITHOUT BURNER		IN	133.38	133.38	133.38	147.38	153.38	168.38	168.38	168.38	202.38	205.38
S	LENGTH WITH STD. BURNER		IN	144.25	144.25	148.75	160.63	167.53	184.75	184.75	185	216	220.68
T	STEAM & FD/WTR. LOCATION		IN	46.75	46.75	46.75	46.75	48	54.75	54.75	54.75	64.813	64.813
U	TUBE REMOVAL FROM FRONT		IN	84	84	84	96	102	114	114	114	143	143
V	LENGTH OVER END PLATES		IN	97	97	97	109	116	129	129	129	160	172
W	BURNER EXTEN'SN. APPROX.	STND. BURNER	IN	32	32	36.5	36.5	36.5	40.75	40.75	40.75	41.25	45.5
X	REAR DOOR SWING CLEARANCE		IN	48	48	48	50	50	54	54	56	60	60
	WATER CAPACITY FLOODED	GAL.	443	438	414	531	527	709	704	746	859	1127	1215
	WATER CAPACITY, OPERATING	GAL.	323	318	348	409	446	577	571	626	765	950	1025
	APPROX. SHIPPING WEIGHT	150 PSI	LBS.	4325	4425	4550	5000	5425	6890	7000	7500	8800	10500
	APPROX. SHIPPING WEIGHT	LOW PRESS.	LBS.	4150	4250	4450	4890	5315	6500	6600	7050	8225	9650

NOTE:1 3" & ABOVE ARE 300# ANSI FLANGE.
 NOTE:2 4" & ABOVE ARE 150# ANSI FLANGE.
 NOTE: DO NOT USE FOR CONSTRUCTION, DIM. [S] & [W] ARE DEPENDENT ON SPECIFIC BURNER SELECTION.

ALL DIMENSIONS ARE IN INCHES
 CERTIFIED DRAWING AVAILABLE UPON REQUEST.
 DIMENSIONS SUBJECT TO CHANGE WITHOUT NOTICE.

	200	250	300	350	400	500	600	700	800	900	1000
A	4	6	6	6	6	6	8	8	8	8	8
A	8	10	10	10	10	10	12	12	12	14	14
A	8	10	10	10	10	10	12	12	12	12	12
B	6	8	8	8	8	8	10	10	10	12	12
C	6	8	8	8	8	8	10	10	10	12	12
D	1.5	1.5	2	2	2	2	2.5	2.5	2.5	2.5	2.5
E	1.25	1.25	1.5	1.5	1.5	1.5	2	2	2	2	2
E	2	2	2	2	2	2	2	2	2	2	2
F	63	63	68	68	76	76	78	78	78	83	83
F	32	32	36	36	42	42	42	42	42	48	48
G	16	16	14	14	15	15	15	15	15	18.5	18.5
G	37.5	37.5	39.5	39.5	41.625	41.625	41.625	41.625	41.625	48.13	48.13
I	47.88	47.88	50.38	50.38	53.5	53.5	54.5	54.5	54.5	60.5	60.5
J	85.75	85.75	90.75	90.75	98	98	100	100	100	109	109
K	54	54	56	56	62	62	60	60	60	64	64
L	176	176	204	204	204	204	252	294	318	321	321
M	30.25	30.25	31.25	31.25	35.25	35.25	52.5	52.5	52.5	53.13	53.13
N	18	18	20	20	24	24	28	32	32	34	34
O	69.25	69.25	74.25	74.25	82.75	82.75	85	85	85	89.75	89.75
P	82	82	85	85	93	93	95	95	95	101	101
Q	206.38	206.38	234.38	234.38	237.38	273.88	297.38	339.38	363.38	366.38	366.38
R	221.75	235.5	263.13	263.13	262.13	303.38	310	352.13	376.13	380.63	380.63
S	64.81	64.81	74.81	74.81	76.88	91.88	87.88	111.88	129.88	144	144
T	144	144	168	168	162	198	198	240	264	264	264
U	161	161	188	188	187.25	223.25	229.88	271.88	295.88	296.25	296.25
V	45.5	59.25	59.25	59.25	64.25	64.25	64.25	64.25	64.25	69.5	69.5
W	64	64	66	66	70	70	70	70	70	73	73
X	1545	1510	1993	1968	2346	2764	3006	3511	3830	4073	3966
	1196	1162	1557	1532	1822	2129	2390	2772	3021	3457	3349
	13950	14400	18250	18575	24500	27125	30000	33300	35700	42300	43250
	12930	13400	17975	18300	24200	26800	29600	32900	35300	40200	41200

BOILER DESIGN: Two-Pass "Scotch Marine" Firetube design with "Semi-Wetback" construction.

Pressure designs for steam are:
 20-150 HP > 450 PSI max.
 200-350 HP > 400 PSI max.
 400-1000 HP > 350 PSI max.

Hot Water pressures models available from 30-160 psi. at 250° F. MAX.
 High pressure, high temperature Section I hot water boilers available also.
 Factory assembled and tested to, ASME code, UL, and CSD-1 standards.

STEAM MODEL TRIM: Safety relief valve, operating pressure control, high limit pressure control with manual reset, steam pressure gauge with syphon, combination pump control and low water cut-off with gauge glass assembly and drain valve, auxiliary low water cut-off with manual reset.

HOT WATER MODEL TRIM: Safety relief valve, operating temperature control, high limit temperature control with manual reset, combination pressure & temperature gauge, low water cut-off control with manual reset.

BURNER: Matched UL listed "forced draft" power burners with factory pre-piped, wired and tested fuel configurations for natural gas, propane (LP) gas, No. 2 (diesel) oil, No. 6 heavy oil or combination of both gas/oil.

MORE MODELS CHOICES SOLUTIONS