

### High Turndown Forced Draft

- Turn downs to 12:1 gas, 10:1 oil
- Natural Gas, Propane, Digester, Waste Gas or Mixed Gas Firing
- #2 - #6 Oil firing (FGR must be off when firing #6 oil)
- Pressure (return flow nozzle) or air atomized oil firing
- Linkage or parallel positioning controls
- Induced FGR for stable combustion with NOx to 12ppm
- Full Modulation
- For Firetube, Watertube, Flextube, Cast Iron and other vessel applications.



### Capacity Ratings

- The JBSX3 offering is shown below. Different fans and motors (5 to 15 hp) can be used as needed.
- Rated input is based on a max air temperature of 90°F, 60 Hz, altitude under 1000 ft.
- Contact factory for 50 Hertz applications and specific boiler applications.

The JBSX3 is available with two different combustion heads, a "T" (10.5") and "A" (12") head. These can be used with any of the five fan and motor size combination as needed. The chart below shows how these can be applied.

JBSX3 Model #	BHP	Rated Input		Standard Turndown			Maximum Turndown		
		Gas MBH	Oil GPH	Gas	#2 Oil Press Atom	#2 Oil Air Atom	Gas	#2 Oil Press Atom	#2 Oil Air Atom
JBSX3* - 125 T	125	5230	37.4	5.0	2.5	5.0	12.0	3.0	10.0
JBSX3* - 129 T	129	5400	38.6	5.0	2.5	5.0	12.0	3.0	10.0
JBSX3* - 131 T	131	5500	39.3	5.0	2.5	5.0	12.0	3.0	10.0
JBSX3* - 140 T	140	5858	41.8	5.0	2.5	5.0	12.0	3.0	10.0
JBSX3* - 143 T	143	6000	42.9	5.0	2.5	5.0	12.0	3.0	10.0
JBSX3* - 150 T	150	6300	45.0	5.0	2.5	5.0	12.0	3.0	10.0
JBSX3* - 155 T	155	6500	46.4	5.0	2.5	5.0	12.0	3.0	10.0
JBSX3* - 167 T	167	7000	50.0	5.0	2.5	5.0	12.0	3.0	10.0
JBSX3* - 175 T	175	7323	52.3	5.0	2.5	5.0	12.0	3.0	10.0
JBSX3* - 180 T	180	7532	53.8	5.0	2.5	5.0	12.0	3.0	10.0
JBSX3* - 191 T	191	8000	57.1	5.0	2.5	5.0	12.0	3.0	10.0
JBSX3* - 200 A	200	8400	60.0	5.0	2.5	5.0	12.0	3.0	10.0
JBSX3* - 215 A	215	9000	64.3	5.0	2.5	5.0	12.0	3.0	10.0
JBSX3* - 225 A	225	9415	67.3	5.0	2.5	5.0	12.0	3.0	10.0
JBSX3* - 240 A	240	10043	71.7	5.0	2.5	5.0	12.0	3.0	10.0
JBSX3* - 250 A	250	10500	75.0	5.0	2.5	5.0	12.0	3.0	10.0
JBSX3* - 275 A	275	11507	82.2	5.0	2.5	5.0	12.0	3.0	10.0
JBSX3* - 323 A	323	13500	96.4	5.0	2.5	5.0	12.0	3.0	10.0
JBSX3* - 325 A	325	13600	97.1	5.0	2.5	5.0	12.0	3.0	10.0

### Model Number Designation: JBSX3 <sup>\*</sup>C - 175 T - 30

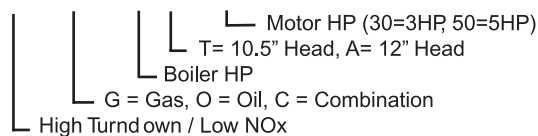

- Gas input based on HHV = 1000, 0.64 specific gravity. Gas Train requirements will vary with insurance and job site conditions.
- Oil input based on #2 oil at 140,000 BTU/gal. Heavy oil rates will be lower, based on 150,000 BTU/gal.
- Heavy oil must have <0.5% sulfur to be used on this burner.

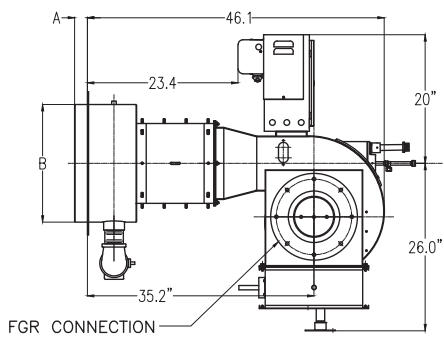

Standard JBSX3 Arrangement Side View

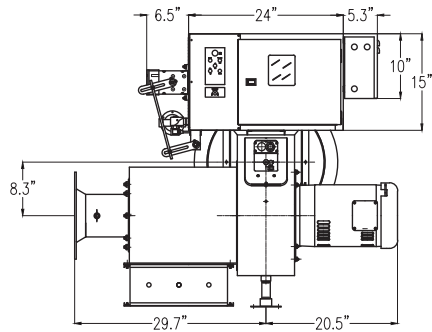

Standard JBSX3 Arrangement End View

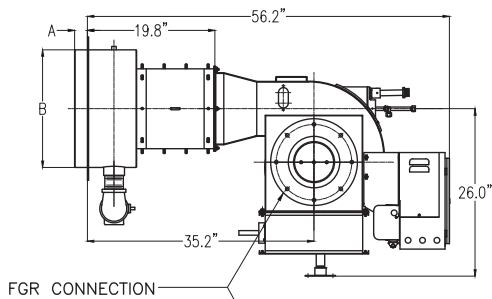

JBSX3 Arrangement With Back Mounted Panel

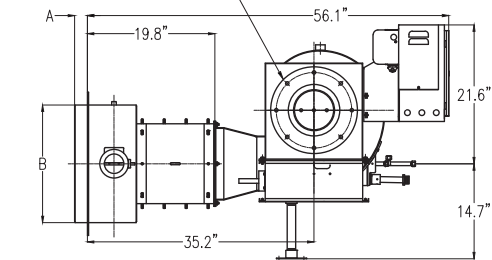

JBSX3 Inverted Arrangement With Back Mounted Panel

	A	B
10.5" Head (T), 2" Insert	2.0	14.5
10.5" Head (T), 7" Insert	7.0	14.5
12" Head (A), 2" Insert	2.0	18.3
12" Head (A), 7" Insert	7.0	18.3

(1) STANDARD UL EQUIPMENT AND IMPORTANT OPTIONS

	Gas	No. 2 Oil		
		Pressure Atomized	Air Atomized	
General	Motor, Fan and Air Inlet Control	X	X	X
	Air Flow Switch	X	X	X
	(2) Burner Mounted Control Panel, Switch and Indicator Lights	X	X	X
	Flame Safety Control	X	X	X
	Infra-red Scanner	X	X	X
	Motor Starter w/overloads (3 PH volt)	X	X	X
Fuel Selector Switch	Dual Fuel Burners Only			
Ignition	Proven Gas Pilot Ignition	X	X	X
	Pilot Solenoid Gas Valve	X	X	X
	Pilot Gas Regulator & Manual Valve	X	X	X
	Pilot Gas Ignition Transformer	X	X	X
Options	Inverted Housing	X	X	X
	Alternate Control Cabinet Positioning	X	X	X
	Remote Control Panel	X	X	X
	Fuel Metering CAM-NETICS II	Opt.	Opt.	Opt.
	Silencer	Opt.	Opt.	Opt.
Gas Fuel	Main Manual Shutoff Valve	X		
	Main Safety Shutoff Valve	X		
	Second Safety Shutoff Valve	X		
	Main Gas Regulator	X		
	Gas Checking Valve	X		
	High and Low Gas Pressure Switches	X		
	Metering Valve	X		
	Normally Open Vent Valve	Opt.		
Leak Test Ports (CSD-1)	X			
Oil Fuel	Oil Drawer Assembly		X	X
	Oil Nozzles		X	X
	Remote Oil Pump		X	Opt.
	Two Safety Shutoff Valves		X	X
	Low Air Atomizing Switch			X
	Low Oil Pressure Switch		X	X
	Oil Pressure Gauge		X	X
	Oil Metering Valve		X	X
	Future Gas Combustion Head		Opt.	Opt.
	Air Compressor			X

1. The configuration of each unit will vary with specific job requirements such as input rating, electrical specification and special agency approval codes. The above chart shows those items standard to a basic burner plus a few options that may be added.  
 2. Indicator lights are "Power On", "Call for Heat", "Fuel On" and "Flame Fail" for hard wired panels. "Alarm", "Low Water", "Power", "Call for Heat", "Ignition On" and "Fuel On" for circuit board light panels.

Essential Ordering Information and Data:

- Power Supply - Confirm 120-60-1 for control circuit and electrical supply for burner motor(s) (voltage, frequency and phase).
- Describe Boiler or Heater to be Fired - Including the manufacturer, model number, furnace pressure and furnace size.
- Firing Rate - Define firing rates in MBH for gas and GPH for oil.
- Fuel to be Burned - Type of gas and/or oil, including the BTU value.
- Approval Agency - UL, FM, IRI (GE GAP), CSD-1, NFPA, Mil spec and local codes, if applicable.
- Flame Safety Control Preferred - Honeywell or Fireye controls. Gas Train Components Preferred - ASCO / ITT, Honeywell or Siemens
- Required Options - Mounting plate, limit controls, etc.