

M SERIES

TECHNICAL DATA INFORMATION PACKET

**INDUSTRIAL
COMBUSTION**

Table of Contents

M Series

Uncontrolled Emissions MG, MM#2, MMG#2

Technical Data Sheet	3
Ratings Table.....	4
Dimensions Table.....	5

M Series

Uncontrolled Emissions MM, MMG

Technical Data Sheet	6
Ratings Table.....	7
Dimensions Table.....	8

M Series

Uncontrolled Emissions ME, MEG

Technical Data Sheet	9
Ratings Table.....	10
Dimensions Table.....	11

Technical Data

M Series

Uncontrolled Emissions Configuration (MG, MM#2, MMG#2)

1.4 - 10.5 MM BTU/H NG; 10 - 75 GPH #2 OIL

UL listed with choice of NFPA, CSD-1, GAP, and FM for U.S. or Canadian units

Standard equipment:	Combustion Control System options:	Fuel options:
3450 RPM motor, panel signal lights (Power On, Main Fuel, Ignition, Flame Failure), dry oven and gasket, combustion air proving switch, high fire air proving switch, 120/1/60 control circuit, burner mounted panel, hinged blast tube with right-hand swing. Gas and gas/oil units only: shipped loose gas train.	Parallel Positioning Combustion Control System with O ₂ Trim and Variable Frequency Drive (VFD)	Main Fuel: Natural gas (MG), #2 oil - air atomized (MM#2) or Combination gas/ #2 oil - air atomized (MMG#2). Igniter Fuel: Natural gas and/or propane. Fuel Changeover Switch: Combination gas/oil units only (MMG#2).

Series Features

◇ Optional Feature



	M-14 to M-22	M-25	M-28 to M-30	M-34 to M-42	M-54 to M-63	M-84 to M-105
Flame Safeguard						
UV Scanner	•	•	•	•	•	•
Mode of Operation						
Full Modulation Firing	•	•	•	•	•	•
Auto-Manual Firing Rate Control	• ¹	• ¹	• ¹	• ¹	• ¹	• ¹
Cam Trim	◇	◇	◇	•	•	•
Ignition						
Gas/Electric Pilot and Ignition Transformer	• ²	• ²	• ²	• ²	• ²	•
Direct Spark (ML)	•	•	•	•	•	
Oil Components						
3-Way Solenoid Valve	•	•	•	•	•	•
2-Way Solenoid Valve	•	•	•	•	•	•
3-Way Motorized POC Valve	◇	◇	◇	◇	◇	◇
2-Way Motorized POC Valve	◇	◇	◇	◇	◇	◇
Atomizing Air Proving Switch	•	•	•	•	•	•
Low Oil Pressure Switch	◇	◇	◇	◇	◇	◇
Burner Mounted Integral Oil/Air System	•	•	•	•	•	•
Gas Components						
Butterfly Rate Control Valve	•	•	•	•	•	•
High & Low Gas Pressure Interlocks	◇	◇	•	•	•	•
Gas Shutoff Cocks (2)	•	•	•	•	•	•
Motorized Valve w/o POC & Solenoid Valve	•	•	•	•		
Motorized Valve w/ POC & Solenoid Valve	◇	◇	◇	◇	•	•

¹ Standard for full modulation; optional on select parallel positioning systems

² Standard for MG and MMG#2 burners

Standard Ratings

M Series

MG - MM#2 - MMG#2: Gas, #2 Oil, Gas/Oil Configuration

	Gas Input MBH	#2 Oil Input GPH	BHP @ 80% Eff.	Blower Motor HP "S" ¹	Blower Motor HP "P" ²	Integral Oil/Air System Motor HP 3 Phase	Standard Gas Train Pipe Size (in.)	Min. Gas Press. ("w.c.) ³	
Model No. & Frame Size									
M-14-1	1,400	10.0	33	1/2	-	3/4	1	10.9	208 / 230 / 460 / 3
M-16-1	1,680	12.0	40	1/2	-	3/4	1	15.7	
M-19-1	1,960	14.0	47	1/2	-	3/4	1 1/2	8.8	
M-22-1	2,200	15.7	52	1/2	-	3/4	1 1/2	10.3	
M-25-2	2,490	18.0	59	2	-	3/4	1 1/2	10.1	
M-28-2	2,800	20.0	67	2	-	3/4	1 1/2	12.0	
M-30-2	3,150	22.5	75	2	-	3/4	1 1/2	14.9	
M-34-3	3,500	25.0	83	2	2	1	1 1/2	19.0	230 / 460 / 3
M-42-3	4,200	30.0	104	2	2	1	2	9.2	
M-54-3	5,600	40.0	133	2	3	1	2	16.1	460 / 3
M-63-3	6,300	45.0	150	3	3	2	2	20.3	
M-84-4	8,400	60.0	200	5	7 1/2	2	2 1/2	18.0	
M-105-4	10,500	75.0	250	7 1/2	7 1/2	2	3	16.0	

¹ Use model "S" up to 0.75" w.c. furnace pressure, consult factory for higher pressures

² Use model "P" up to 2.0" w.c. furnace pressure, consult factory for higher pressures

³ Standard gas pressures only, consult factory for lower gas pressures

Input is based on fuel BTU content, listed furnace pressure and altitude of 2,000 feet or less. If altitude > 2,000 feet and < 8,000 feet, derate capacity 4% per 1,000 feet over 2,000. Consult factory for higher altitudes. If furnace pressure exceeds listed value, derate capacity 5% for every 0.5" w.c. of pressure in excess of stated. Consult factory if derate exceeds 20%. Gas input is based on natural gas with 1,000 BTU/cu.ft. and 0.60 gravity. For total pressure at manifold, add furnace pressure. Oil input based on 140,000 BTU/gal and the aforementioned conditions. Consult factory for 50 Hz. applications.

Standard Dimensions

M Series

MG - MM#2 - MMG#2: Gas, #2 Oil, Gas/Oil Configuration

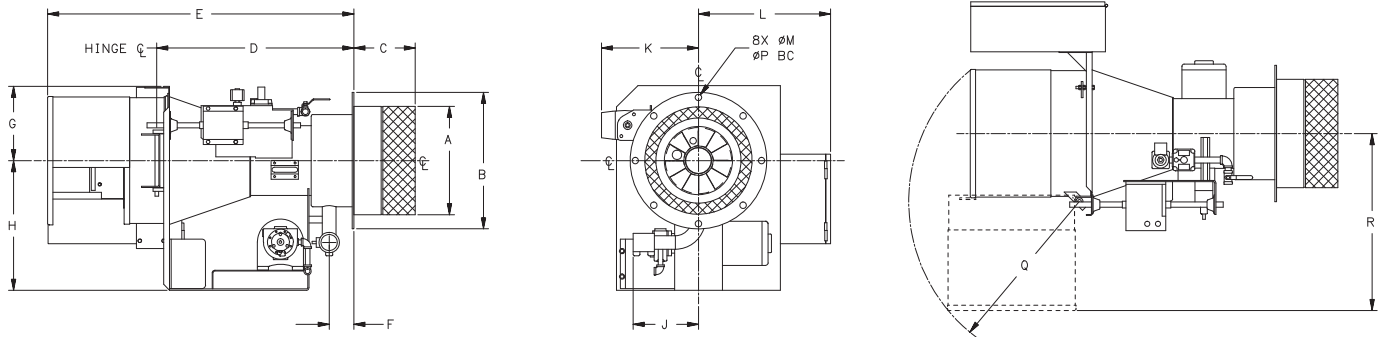

DIM	Burner Frame Size				
	Size 1	Size 2	Size 3	Size 4	
Length in inches					
Overall length	E	40	41 3/4	44 7/8	54 3/4
Width in inches					
Center line to right side	K	14 7/8	13 7/8	14 3/8	15 1/8
Center line to left side	L	18	19 3/4	19 3/8	24
Height in inches					
Center line to top	G	9 1/4	10	10 3/4	16 1/2
Center line to bottom	H	12 3/8	15 1/2	19	23
Dry oven dimensions in inches					
Diameter of dry oven	A	12	13	15 7/8	19
Depth of dry oven	C	6	6	9	10
Mounting flange dimensions in inches					
Diameter	B	15	16	20	23
Flange to hinge	D	23 1/2	25 3/8	28 7/8	35 1/8
Bolt hole diameter	M	1/2	1/2	15/16	15/16
Bolt circle diameter	P	13 3/4	14 1/2	18 1/2	21
Hinge swing dimensions in inches					
Hinge swing radius	Q	23	24	25	33
Center line to outer hinge clearance	R	24 1/2	25 3/8	26	34 1/8
Gas inlet dimensions in inches					
Mounting flange to gas inlet	F	1 7/8	1 7/8	3 5/8	3 3/4

Accompanying dimensions, while sufficiently accurate for layout purposes, must be confirmed for construction.

Technical Data

M Series

Uncontrolled Emissions Configuration (MM, MMG)

1.4 - 10.5 MM BTU/H NG; 9.6 - 72.4 GPH #2-5 OIL

UL listed with choice of NFPA, CSD-1, GAP, and FM for U.S. or Canadian units

Standard equipment:	Combustion Control System options:	Fuel options:
3450 RPM motor, panel signal lights (Power On, Main Fuel, Ignition, Flame Failure), dry oven and gasket, combustion air proving switch, high fire air proving switch, 120/1/60 control circuit, burner mounted panel, hinged blast tube with right-hand swing. Gas and gas/oil units only: shipped loose gas train.	Parallel Positioning Combustion Control System with O ₂ Trim and Variable Frequency Drive (VFD)	Main Fuel: #2-5 oil - Air atomized (MM) or Combination natural gas/ #2-5 oil - air atomized (MMG). Igniter Fuel: Natural gas and/or propane. Fuel Changeover Switch: Combination gas/oil units only (MMG).

Series Features

◊ Optional Feature



	M-14 to M-22	M-25	M-28 to M-30	M-34 to M-42	M-54 to M-63	M-84 to M-105
Flame Safeguard						
IR Scanner	•	•	•	•	•	•
Mode of Operation						
Full Modulation Firing	•	•	•	•	•	•
Auto-Manual Firing Rate Control	• ¹	• ¹	• ¹	• ¹	• ¹	• ¹
Cam Trim	◊	◊	◊	•	•	•
Ignition						
Gas/Electric Pilot and Ignition Transformer	• ²	• ²	• ²	• ²	• ²	•
Direct Spark (MM)	•	•	•	•	•	
Oil Components						
3-Way Solenoid Valve	•	•	•	•	•	•
2-Way Solenoid Valve	•	•	•	•	•	•
3-Way Motorized POC Valve	◊	◊	◊	◊	◊	◊
2-Way Motorized POC Valve	◊	◊	◊	◊	◊	◊
Atomizing Air Proving Switch	•	•	•	•	•	•
Low Oil Pressure Switch	◊	◊	◊	◊	◊	◊
Burner Mounted Integral Oil/Air System	•	•	•	•	•	•
Nozzle Line Heater with Cold Oil Lockout	• ³	• ³	• ³	• ³	• ³	• ³
Gas Components						
Butterfly Rate Control Valve	•	•	•	•	•	•
High & Low Gas Pressure Interlocks	◊	◊	•	•	•	•
Gas Shutoff Cocks (2)	•	•	•	•	•	•
Motorized Valve w/o POC & Solenoid Valve	•	•	•	•		
Motorized Valve w/ POC & Solenoid Valve	◊	◊	◊	◊	•	•

¹ Standard for full modulation; optional on select parallel positioning systems

² Standard for MM and MMG burners

³ Standard for #4-5 oil only

Standard Ratings

M Series

MM - MMG: #2-5 Oil, Gas/Oil Configuration

	Gas Input MBH	#2-5 Oil Input GPH	BHP @ 80% Eff.	Blower Motor HP "S" ¹	Blower Motor HP "P" ²	Integral Oil/Air System Motor HP 3 Phase	Nozzle Line Heater 3 Phase (kw)	Standard Gas Train Pipe Size (in.)	Min. Gas Press. ("w.c.) ³	
Model No. & Frame Size										
M-14-1	1,400	9.6	33	1/2	-	3/4	3	1	10.9	208 / 230 / 460 / 3
M-16-1	1,680	11.6	40	1/2	-	3/4	3	1	15.7	
M-19-1	1,960	13.5	47	1/2	-	3/4	3	1 1/2	8.8	
M-22-1	2,200	15.2	52	1/2	-	3/4	3	1 1/2	10.3	
M-25-2	2,490	17.4	59	2	-	3/4	3	1 1/2	10.1	
M-28-2	2,800	19.3	67	2	-	3/4	3	1 1/2	12.0	
M-30-2	3,150	21.7	75	2	-	3/4	3	1 1/2	14.9	
M-34-3	3,500	24.1	83	2	2	1	3	1 1/2	19.0	230 / 460 / 3
M-42-3	4,200	29.0	104	2	2	1	3	2	9.2	
M-54-3	5,600	38.6	133	2	3	1	3	2	16.1	460 / 3
M-63-3	6,300	43.5	150	3	3	2	3	2	20.3	
M-84-4	8,400	58.0	200	5	7 1/2	2	5	2 1/2	18.0	
M-105-4	10,500	72.4	250	7 1/2	7 1/2	2	5	3	16.0	

¹ Use model "S" up to 0.75" w.c. furnace pressure, consult factory for higher pressures

² Use model "P" up to 2.0" w.c. furnace pressure, consult factory for higher pressures

³ Standard gas pressures only, consult factory for lower gas pressures

Input is based on fuel BTU content, listed furnace pressure and altitude of 2,000 feet or less. If altitude > 2,000 feet and < 8,000 feet, derate capacity 4% per 1,000 feet over 2,000. Consult factory for higher altitudes. If furnace pressure exceeds listed value, derate capacity 5% for every 0.5" w.c. of pressure in excess of stated. Consult factory if derate exceeds 20%. Gas input is based on natural gas with 1,000 BTU/cu.ft. and 0.60 gravity. For total pressure at manifold, add furnace pressure. Oil input based on 145,000 BTU/gal and the aforementioned conditions. Consult factory for 50 Hz. applications.

Standard Dimensions

M Series

MM - MMG: #2-5 Oil, Gas/Oil Configuration

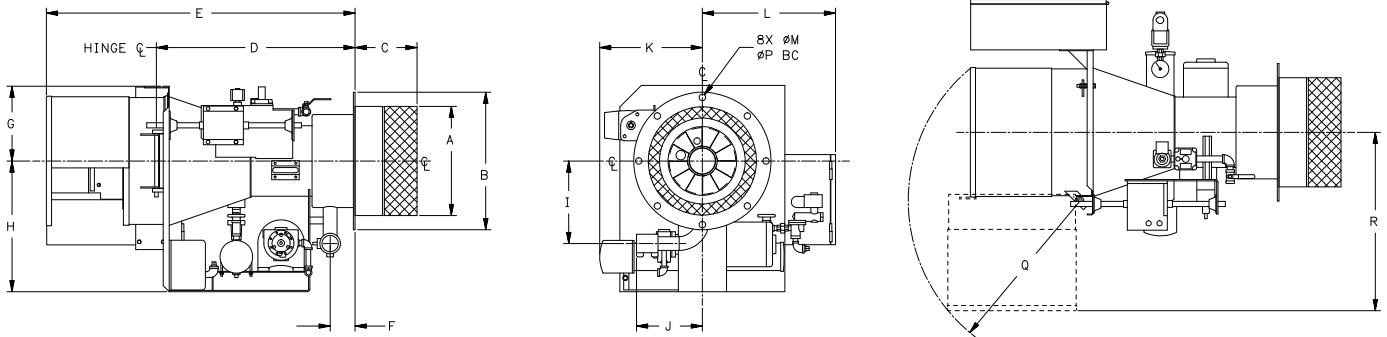

DIM	Burner Frame Size				
	Size 1	Size 2	Size 3	Size 4	
Length in inches					
Overall length	E	40	41 3/4	44 7/8	54 3/4
Width in inches					
Center line to right side	K	15 5/8	14 1/2	15	15 3/4
Center line to left side	L	18	19 3/4	19 3/8	24
Height in inches					
Center line to top	G	9 1/4	10	10 3/4	16 1/2
Center line to bottom	H	12 3/8	15 1/2	19	23
Dry oven dimensions in inches					
Diameter of dry oven	A	12	13	15 7/8	19
Depth of dry oven	C	6	6	9	10
Mounting flange dimensions in inches					
Diameter	B	15	16	20	23
Flange to hinge	D	23 1/2	25 3/8	28 7/8	35 1/8
Bolt hole diameter	M	1/2	1/2	15/16	15/16
Bolt circle diameter	P	13 3/4	14 1/2	18 1/2	21
Hinge swing dimensions in inches					
Hinge swing radius	Q	23	24	25	33
Center line to outer hinge clearance	R	24 1/2	25 3/8	26	34 1/8
Gas inlet dimensions in inches					
Mounting flange to gas inlet	F	1 7/8	1 7/8	3 5/8	3 3/4

Accompanying dimensions, while sufficiently accurate for layout purposes, must be confirmed for construction.

Technical Data

M Series

Uncontrolled Emissions Configuration (ME, MEG)

1.4 - 10.5 MM BTU/H NG; 9.3 - 70 GPH #2-6 OIL

UL listed with choice of NFPA, CSD-1, GAP, and FM for U.S. or Canadian units

* ME & MEG 14-30 are not UL listed

Standard equipment:	Combustion Control System options:	Fuel options:
3450 RPM motor, panel signal lights (Power On, Main Fuel, Ignition, Flame Failure), dry oven and gasket, combustion air proving switch, high fire air proving switch, 120/1/60 control circuit, burner mounted panel, hinged blast tube with right-hand swing. Gas and gas/oil units only: shipped loose gas train.	Parallel Positioning Combustion Control System with O ₂ Trim and Variable Frequency Drive (VFD)	Main Fuel: #6 oil - air atomized (ME) or Combination natural gas/ #6 oil - air atomized (MEG). Igniter Fuel: Natural gas and/or propane. Fuel Changeover Switch: Combination gas/oil units only (MEG).

Series Features

◇ Optional Feature



	M-14 to M-22	M-25	M-28 to M-30	M-34 to M-42	M-54 to M-63	M-84 to M-105
Flame Safeguard						
IR Scanner	•	•	•	•	•	•
Mode of Operation						
Full Modulation Firing	•	•	•	•	•	•
Auto-Manual Firing Rate Control	• ¹	• ¹	• ¹	• ¹	• ¹	• ¹
Cam Trim	◇	◇	◇	•	•	•
Ignition						
Gas/Electric Pilot and Ignition Transformer	• ²	• ²	• ²	• ²	• ²	•
Oil Components						
3-Way Solenoid Valve	•	•	•	•	•	•
2-Way Solenoid Valve	•	•	•	•	•	•
3-Way Motorized POC Valve	◇	◇	◇	◇	◇	◇
2-Way Motorized POC Valve	◇	◇	◇	◇	◇	◇
Atomizing Air Proving Switch	•	•	•	•	•	•
Low Oil Pressure Switch	•	•	•	•	•	•
Burner Mounted Oil Metering System	•	•	•	•	•	•
Separately Mounted Air Compressor Module				•	•	•
Nozzle Line Heater with Cold Oil Lockout	• ³	• ³	• ³	• ³	• ³	• ³
Gas Components						
Butterfly Rate Control Valve	•	•	•	•	•	•
High & Low Gas Pressure Interlocks	◇	◇	•	•	•	•
Gas Shutoff Cocks (2)	•	•	•	•	•	•
Motorized Valve w/o POC & Solenoid Valve	•	•	•	•		
Motorized Valve w/ POC & Solenoid Valve	◇	◇	◇	◇	•	•

¹ Standard for full modulation; optional on select parallel positioning systems

² Standard for ME and MEG burners

³ Standard for #4-5 oil only

Standard Ratings

M Series

ME - MEG: #2-6 Oil, Gas/Oil Configuration

	Gas Input MBH	#2-6 Oil Input GPH	BHP @ 80% Eff.	Blower Motor HP "S" ¹	Blower Motor HP "P" ²	Integral Oil/Air System Motor HP 3 Phase	Separate Compressor Module Motor HP	Oil Metering System Motor HP	Nozzle Line Heater 3 Phase (kw)	Standard Gas Train Pipe Size (in.)	Min. Gas Press. ("w.c.) ³	
Model No. & Frame Size												
M-14-1	1,400	9.3	33	1/2	-	3/4	-	-	3	1	10.9	208 / 230 / 460 / 3
M-16-1	1,680	11.2	40	1/2	-	3/4	-	-	3	1	15.7	
M-19-1	1,960	13.1	47	1/2	-	3/4	-	-	3	1 1/2	8.8	
M-22-1	2,200	14.7	52	1/2	-	3/4	-	-	3	1 1/2	10.3	
M-25-2	2,490	16.8	59	2	-	3/4	-	-	3	1 1/2	10.1	
M-28-2	2,800	18.7	67	2	-	3/4	-	-	3	1 1/2	12.0	
M-30-2	3,150	21.0	75	2	-	3/4	-	-	3	1 1/2	14.9	
M-34-3	3,500	23.3	83	2	2	-	3	1/2	3	1 1/2	19.0	230 / 460 / 3
M-42-3	4,200	28.0	104	2	2	-	3	1/2	3	2	9.2	
M-54-3	5,600	37.3	133	2	3	-	3	1/2	3	2	16.1	460 / 3
M-63-3	6,300	42.0	150	3	3	-	3	1/2	3	2	20.3	
M-84-4	8,400	56.0	200	5	7 1/2	-	3	1/2	5	2 1/2	18.0	
M-105-4	10,500	70.0	250	7 1/2	7 1/2	-	3	1/2	5	3	16.0	

¹ Use model "S" up to 0.75" w.c. furnace pressure, consult factory for higher pressures

² Use model "P" up to 2.0" w.c. furnace pressure, consult factory for higher pressures

³ Standard gas pressures only, consult factory for lower gas pressures

Input is based on fuel BTU content, listed furnace pressure and altitude of 2,000 feet or less. If altitude > 2,000 feet and < 8,000 feet, derate capacity 4% per 1,000 feet over 2,000. Consult factory for higher altitudes. If furnace pressure exceeds listed value, derate capacity 5% for every 0.5" w.c. of pressure in excess of stated. Consult factory if derate exceeds 20%. Gas input is based on natural gas with 1,000 BTU/cu.ft. and 0.60 gravity. For total pressure at manifold, add furnace pressure. Oil input based on 150,000 BTU/gal and the aforementioned conditions. Consult factory for 50 Hz. applications.

Standard Dimensions

M Series

ME - MEG: #2-6 Oil, Gas/Oil Configuration

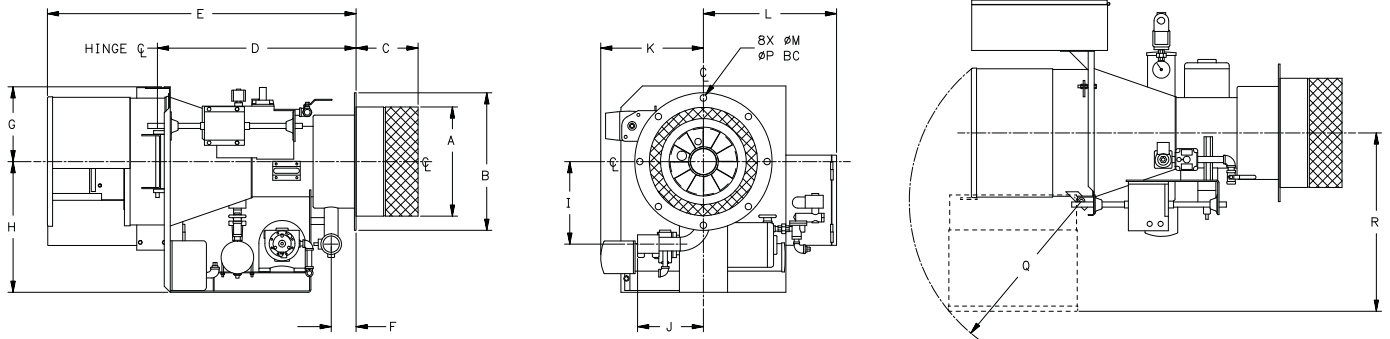

DIM	Burner Frame Size				
	Size 1	Size 2	Size 3	Size 4	
Length in inches					
Overall length	E	40	41 3/4	44 7/8	54 3/4
Width in inches					
Center line to right side	K	15 5/8	14 1/2	15	15 3/4
Center line to left side	L	18	19 3/4	19 3/8	24
Height in inches					
Center line to top	G	9 1/4	10	10 3/4	16 1/2
Center line to bottom	H	12 3/8	15 1/2	19	23
Dry oven dimensions in inches					
Diameter of dry oven	A	12	13	15 7/8	19
Depth of dry oven	C	6	6	9	10
Mounting flange dimensions in inches					
Diameter	B	15	16	20	23
Flange to hinge	D	23 1/2	25 3/8	28 7/8	35 1/8
Flange to gas inlet	F	1 7/8	1 7/8	3 5/8	3 3/4
Bolt hole diameter	M	1/2	1/2	15/16	15/16
Bolt circle diameter	P	13 3/4	14 1/2	18 1/2	21
Hinge swing dimensions in inches					
Hinge swing radius	Q	23	24	25	33
Center line to outer hinge clearance	R	24 1/2	25 3/8	26	34 1/8
Gas inlet dimensions in inches					
Mounting flange to gas inlet	F	1 7/8	1 7/8	3 5/8	3 3/4

Accompanying dimensions, while sufficiently accurate for layout purposes, must be confirmed for construction.

INDUSTRIAL COMBUSTION

351 21st Street, Monroe, WI 53566 USA
608.325.3141 · info@ind-comb.com
ind-comb.com