



HURST

BOILER & WELDING CO., INC.

Available for All
Horizontal Fire-Tube Boilers

HURST SERIES STACKMASTER

Integrated Internal Design
Factory Installed
Instant Energy Savings

INCREASE OVERALL
EFFICIENCY

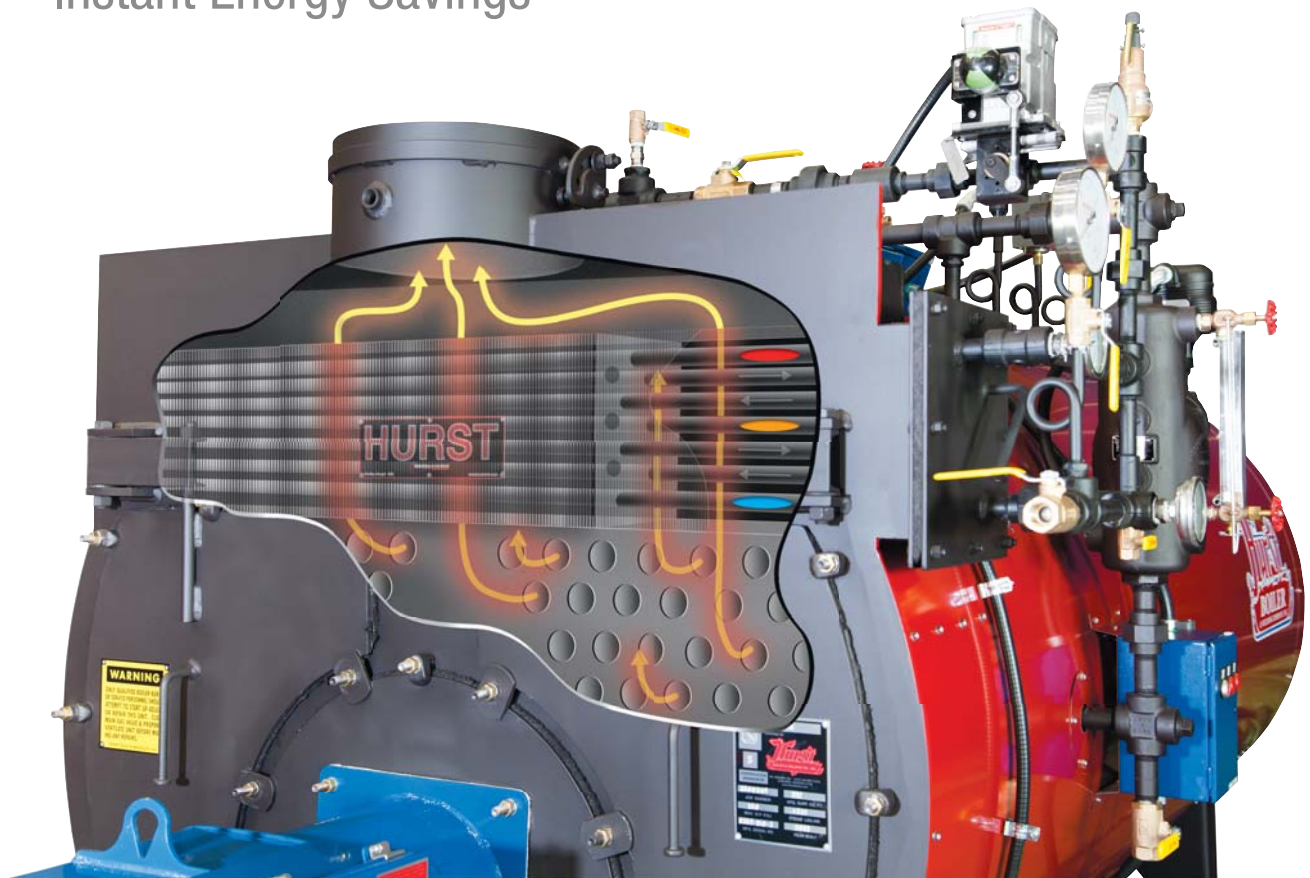

Lower Stack Temperatures

Heat Recovery
Reduce Energy Consumption

HURST PERFORMANCE SERIES BOILERS

The Hurst internal stack economizer is a factory-optional device that is designed to increase the operating efficiency of a boiler, cutting down on its operational costs over the lifetime of the boiler.

Boilers operate by heating water to make steam, and using that steam for heating, processing or power generation. For the most part, a boiler is fairly efficient, but there is some heat loss when the flu gasses resulting from combustion are vented. The spent gases after combustion are quite hot, often very hot, and when they are simply vented out the exhaust stack, this represents lost heat for the boiler system.

The Hurst stack economizer acts as a waste heat recovery device, ensuring that this available heat does not go unused. Instead, the heat is recovered to essentially preheat the boiler's make-up water.

One could think of this *must have* option as a built in feedwater heater; ensuring that the make-up water used to replenish the boiler is pre-heated to near boiling temperatures, so that the boiler does not have to expend as much energy heating it to steam.

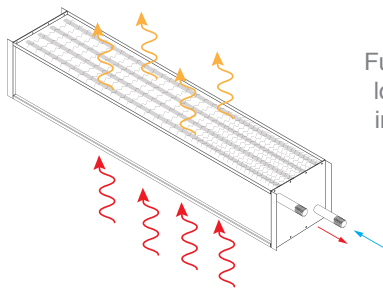

Fully trimmed w/ syphon loop / pressure gauge, in-out thermometers & stop valve.

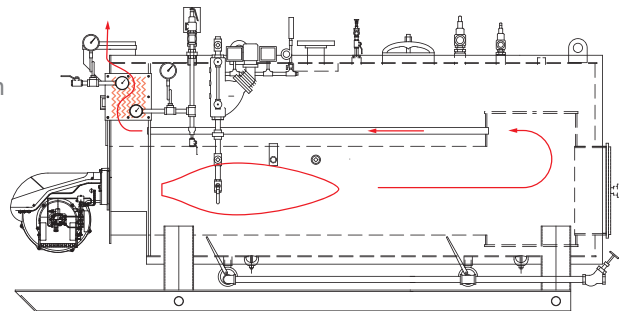

Using an economizer does not just prevent heat loss — it can also extend the life of the boiler. Stresses from using cooler temperature make-up water, known as “thermal shock”, can subject wear and tear on the boiler’s structural integrity over time. This hammering “shock” effect occurs as the boiler’s fixed tube-sheets and fire-tubes rapidly contract from the sudden make-up of cooler temperature water. However, when this water is pre-heated, the temperature differential is far less extreme, putting less strain on the boiler and giving it a longer operating life.



Since even small boiler systems today can be expensive to repair or replace, this innovative design adds to overall savings and protection of the entire boiler system.

FACTORY INSTALLED

No additional on-site installation cost

“One could think of this as a built in feedwater heater; ensuring that the make-up water used to replenish the boiler is pre-heated to near boiling temperatures.”

HBC-09533
03/2014



HURST BOILER & Welding Co., Inc.

100 Boilermaker Lane • Coolidge, GA 31738-0530
Tel: (229) 346-3545 • Fax: (229) 346-3874
email: info@hurstboiler.com